

PEG/J AFTERCARE GUIDELINE

Duodopa® (levodopa – carbidopa)
For Healthcare Professionals

This guide provides best practices for PEG-J aftercare to minimise the potential for PEG-J related complications in your patients.

Please read this guideline carefully and for further instructions refer to the device pump.

Duodopa® (levodopa – carbidopa intestinal gel) is indicated for the treatment of advanced levodopa-responsive Parkinson's disease with severe motor fluctuations and hyper-/dyskinesia when available combinations of Parkinson medicinal products have not given satisfactory results.

Duodopa® (levodopa – carbidopa intestinal gel) is a gel for continuous intestinal administration.

For administration of Duodopa® (levodopa – carbidopa intestinal gel) only the CADD-Legacy 1400 pump (CE 0473) should be used. For long-term administration, the gel should be administered with a portable pump directly into the duodenum or upper jejunum by a permanent tube via percutaneous endoscopic gastrostomy with an outer transabdominal tube and an inner intestinal tube.

PROCEDURE

A. Day of placement (first 24 hours)

The Duodopa® (levodopa – carbidopa intestinal gel) treatment can normally be initiated directly after uncomplicated PEG/J placement, after consultation with the gastroenterologist. Oral feeding is possible 2 hours after PEG/J placement. Do not change the wound dressing during the first 24 hours unless necessary. Observe for signs of complications such as pain and bleeding.

B. Daily procedure, day 1-10

Wound dressing should be performed under good aseptic conditions once a day, for the first 7-10 days. Collect the material in advance and open the dressing packs.

1. Disinfect hands and put on disposable gloves. Remove the dressing, open the retention plate and release the tube from the plate.
2. Dispose the gloves, disinfect hands and put on new gloves.
3. If there are any signs of complications, inform a physician. For list of complications, see section D.
4. Clean (aseptic technique) and disinfect the wound. Leave the area as dry as possible.
5. Carefully push the tube 3-4 cm into the stomach and gently pull back until you feel resistance of the internal retention plate (to avoid buried bumper). Do not twist the tube.
6. Apply a Y-dressing and replace the retention plate allowing free movement of 5-10 mm. Apply a sterile dressing. Secure the tube to the dressing with a plaster or surgical tape.

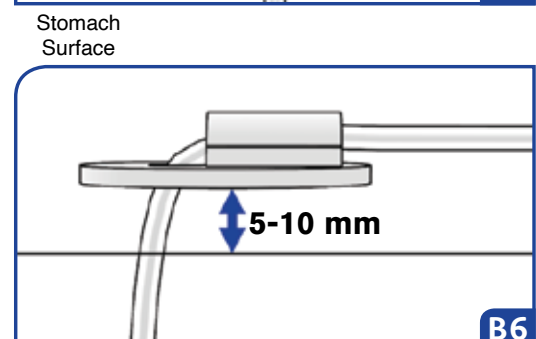
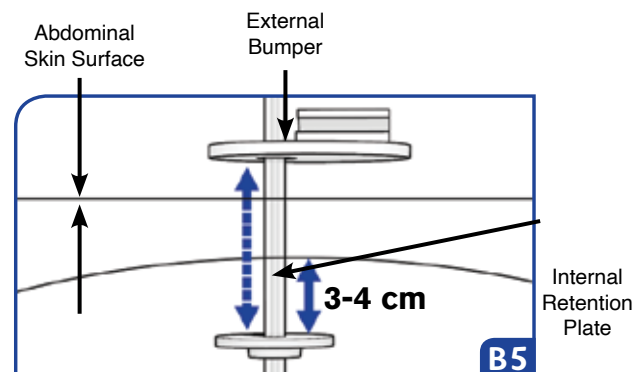
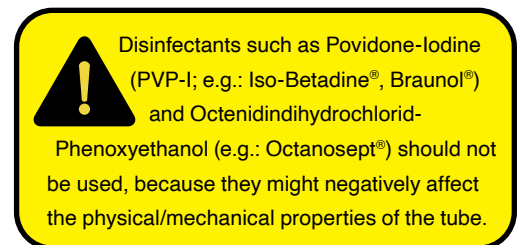

PROCEDURE (continued)

C. Continuous care, every 2-3 days

After initial wound healing this procedure should be performed every 2-3 days. Daily dressing is no longer necessary.

1. **Remove the dressing, release the external retention plate to allow free movement of the PEG/J tube. Carefully push the tube 3-4 cm into the stomach and gently pull back until you feel resistance of the internal retention plate. Do not twist the tube.**
2. If there are any signs of complications, inform a physician. For list of complications, see section D.
3. **Replace the retention plate allowing free movement of 5-10 mm. Apply a Y-dressing. A plaster fixation is recommended for agitated patients.**

Please note:

- Washing or showering with regular soap and water is possible two weeks after insertion of PEG. Always leave the area clean and dry!
- Bathing and swimming (after complete initial wound healing) is possible. Fix tube securely with transparent adhesive dressing. Always leave the area clean and dry!

D. Most common complications and actions to take

General:

- Circular erythema less than 5 mm in diameter is normal and not necessarily a sign of wound infection (daily, careful observation).
- Never apply an ointment on a PEG stoma nor an inflamed PEG wound.

If you are not sure, please consult a physician.

Encrusted dressing – remove with 0.9% saline solution.

Residual tape – remove with disinfection spray (in special cases with surgical spirit – on intact skin only).

Signs of inflammation – change the dressing twice a day and take a swab if necessary. Severe cases: systemic antibiotic treatment.

Severe discharge – keep the wound as dry as possible, change the dressing several times daily as necessary and interpose multiple Y-dressings.

Over granulation tissue – remove only if there are complications (either by surgery or cauterization: Silver Nitrate).

Reference:

Duodopa SmPC January 2021.

To report any side effects for Duodopa® please contact:
AbbVie Biopharmaceuticals GmbH:
Hot line: 00966 55 828 2010 Mailbox: MEAPV@abbvie.com

National Pharmacovigilance Center Saudi Food and Drug Authority.
Fax: +966 11 205 7662
SFDA Unified Call Center: 19999
E-mail: npc.drug@sfda.gov.sa
Website: <https://ade.sfda.gov.sa/>

